

用途/Typical applications: 光学仪器、调焦照相机、指纹锁、自动节能器、水表IC卡、礼品玩具、办公设备、家用电器、执行器

Optical equipment, Monitoring cameras, Kind of finger-electroni locks, Automatic energy savingbath, Water IC card, Toys and gifts. Office equipment, Household appliances, Automatic actuator.

外形尺寸 APPEARANCE SIZE

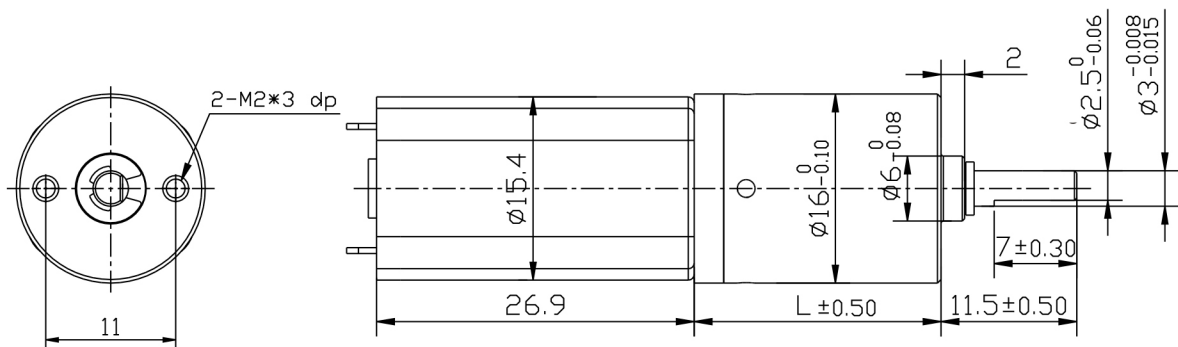

齿轮箱数据 Gearbox data

减速箱级数 Number of stages	1 减速比 Stages reduction	2 减速比 Stages reduction	3 减速比 Stages reduction	4 减速比 Stages reduction	5 减速比 Stages reduction
减速比 Reduction ratio	3.5、4.75	12.3、16、19、22.5	42.8、64、76、90、107	150、256、304、361、428	712、1024、1216、1444、1715、2036、2418
减速比 Reduction ratio	13.7	17.3	20.9	24.5	28.1
最大运转力矩 Max. Running torque	1.0kgf.cm	1.5kgf.cm	4.0kgf.cm	4.0kgf.cm	4.0kgf.cm
最大破坏力矩 Max. Gear breking torque	3.0kgf.cm	4.5kgf.cm	12kgf.cm	12kgf.cm	12kgf.cm
最高齿轮效率 Max. Gearing efficiency	90%	81%	73%	65%	59%

其它减速比请致电或邮件给我司技术部 Other reduction ratio please telephone or e-mail to our engineering department.

马达参数 Motor data

马达型号 Motor Model	电 压 Rated Volt. V	空 载 No load		负 载 Load torque				堵 转 Stall torque	
		电 流 Current	转 速 Speed	电 流 Current	转 速 Speed	扭 矩 Torque	输出功率 Output power	扭 矩 Torque	电 流 Current
		mA	r/min	mA	r/min	gf. cm	W	gf. cm	mA
RF-050039000	3	≤120	9200	≤370	7100	7.3	0.5	32.2	1250
RF-050069000	6	≤50	9000	≤180	7000	7.5	0.52	32	600
RF-050129000	12	≤20	9400	≤90	7200	7.2	0.5	31.4	280
RF-0501212000	12	≤36	12000	≤160	9600	10	0.96	50	580
RF-0502414000	24	≤30	14000	≤100	10500	12	1.2	49	350

- 马达和齿轮箱装配成减速电机后输出扭矩 = 马达扭矩X减速比X齿轮效率;输出转速 = 马达转速 / 减速比 .
- After connecting motor and gearbox which is named gearmotor the output torque: motor torque X reduction ratio X gearing efficiency; output speed: motor speed/reduction ratio .