

- Note:**
- 1、外壳材料: 锌合金 Housing material: metal
 - 2、齿轮间隙, 在空载时: $\leq 1.2^\circ$ Backlash, at no-load: $\leq 1.2^\circ$
 - 3、输出轴轴承: 套管轴承 Bearing at output: Sleeve bearings
 - 4、输出轴的径向间隙: $\leq 0.05\text{mm}$ Radial play of shaft: $\leq 0.05\text{mm}$
 - 5、输出轴轴向间隙: $\leq 0.3\text{mm}$ Thrust play shaft: $\leq 0.3\text{mm}$
 - 6、如果电机在低转速、高速比的组合下, 负载力矩高于600kgf.cm, 会损坏齿轮箱齿轮。
When the motors using at low speed, high gear ratio will cause gear motor torque more than 600kgf.cm. At this torque the gears will be broken easily. Be noted.
 - 5、用途/Typical applications: 监控云台/云台、烘烤架、烤炉、清洗机、垃圾处理、捆钞机、医疗食品、稳压器、游戏机、灌流泵、办公设备、家用电器
Pan/Tilt camera, Grill, Oven, Cleaning machine, Garbage disposers, Packing bank note machine, Coffee machine, Medical machine, Manostat, Amusement equipment, infusion pumps, Office equipment, Household appliances, Automatic actuator.

外形尺寸 APPEARANCE SIZE

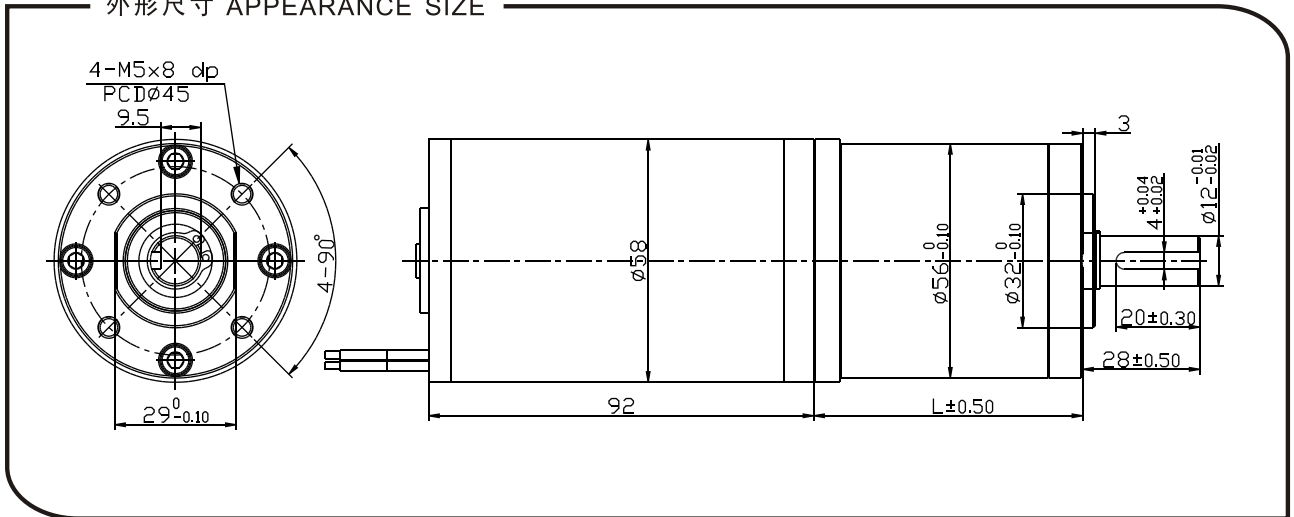

齿轮箱数据 Gearbox data

减速箱级数 Number of stages	1 减速比 Stages reduction	2 减速比 Stages reduction	3 减速比 Stages reduction	4 减速比 Stages reduction	5 减速比 Stages reduction
减速比 Reduction ratio	3.6、4.3	13、19.2、22.7	46.7、69、 102 、121	198、276、326、409、513	843、995、1567、1966、2321、3439
减速比 Reduction ratio	35.3	49.2	63.1	77.0	93.4
最大运转力矩 Max. Running torque	50kgf.cm	100kgf.cm	200kgf.cm	200kgf.cm	200kgf.cm
最大破坏力矩 Max. Gear breking torque	150kgf.cm	300kgf.cm	600kgf.cm	600kgf.cm	600kgf.cm
最高齿轮效率 Max. Gearing efficiency	90%	81%	73%	65%	59%

其它减速比请致电或邮件给我司技术部 Other reduction ratio please telephone or e-mail to our engineering department.

马达参数 Motor data

马达型号 Motor Model	电压 Rated Volt. V	空载 No load		负载 Load torque				堵转 Stall torque	
		电流 Current	转速 Speed	电流 Current	转速 Speed	扭矩 Torque	输出功率 Output power	扭矩 Torque	电流 Current
		mA	r/min	mA	r/min	gf.cm	W	gf.cm	A
ZY58123000	12	≤ 480	3000	≤ 4600	2418	1508	38.1	7594	21.1
Zy58243000	24	≤ 260	3000	≤ 2620	2412	1562	39.5	8392	12.4

- 马达和齿轮箱装配成减速电机后输出扭矩 = 马达扭矩X减速比X齿轮效率; 输出转速 = 马达转速 / 减速比 .
- After connecting motor and gearbox which is named gearmotor the output torque: motor torque X reduction ratio X gearing efficiency; output speed: motor speed/reduction ratio .