

MG-555 直流减速电机 DC GEAR MOTOR Series **SGMADA**®



电压/Main voltage: 3VDC、6VDC、9VDC、12VDC、24VDC、36VDC

用途/Typical applications: 焊接机、垃圾处理机、咖啡机、印刷机、稳压机、碎纸机、输卡机、中央空调阀门、办公设备、家用设备、执行器  
Central ari-conditioning valve, Amusement equipment, Coinrefund devices, Grill, Oven, Peristaltic pumps, ATM bank automatic system, Robot, Medical equipment, Office equipment, Household appliances, Automatic actuator.

重量/Weight: 450~500g/pcs(approx)

包装外形尺寸/Packing details: CTN size: 55X35X18cm 24pcs/CTN G.W.13kgs

外形尺寸 APPEARANCE SIZE

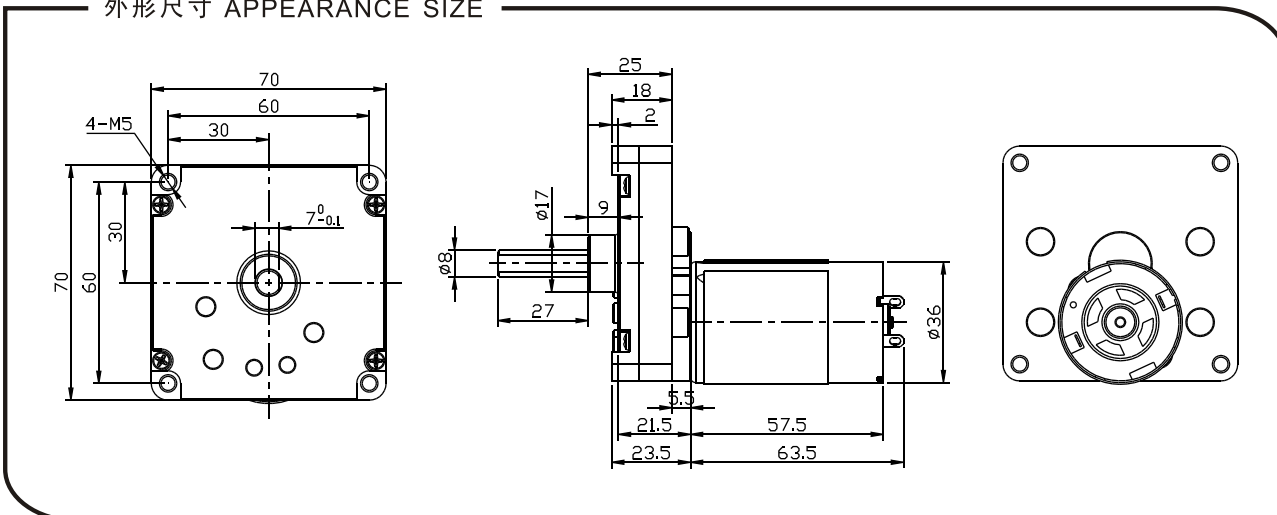

齿轮箱数据 Gearbox data

减速箱级数 Number of stages	3 减速比 Stages reduction	4 减速比 Stages reduction	5 减速比 Stages reduction
减速比 Reduction ratio	13、17.5、25、39、55	90、128、170、190、239	331、478、718
最大运转力矩 Max. Running torque	20kgf.cm	30kgf.cm	50kgf. cm
最大破坏力矩 Max. Gear breking torque	60kgf.cm	90kgf.cm	150kgf.cm
最高齿轮效率 Max. Gearing efficiency	73%	65%	59%

其它减速比请致电或邮件给我司技术部 Other reduction ratio please telephone or e-mail to our engineering department.

马达参数 Motor data

马达型号 Motor Model	电压 Rated Volt. V	空载 No load		负载 Load torque				堵转 Stall torque	
		电流 Current	转速 Speed	电流 Current	转速 Speed	扭矩 Torque	输出功率 Output power	扭矩 Torque	电流 Current
		mA	r/min	mA	r/min	gf. cm	W	gf. cm	MA
MG-555123000	12	≤140	3000	≤800	2200	150	3.3	600	3000
MG-555124500	12	≤220	4500	≤1200	3300	220	7.2	880	4800
MG-555126000	12	≤350	6000	≤2000	4500	300	13.5	1200	6000
MG-555243000	24	≤70	3000	≤400	2200	150	3.3	600	1600
MG-555244500	24	≤110	4500	≤600	3300	220	7.2	880	3000
MG-555246000	24	≤180	6000	≤1000	4500	300	13.5	1200	4000

· 这张表格只列出部分电机参数，想了解更多具体参数请参照95页。

· This table lists some motors parameters, otheers please refer to specific parameters of Page 95.

· 马达和齿轮箱装配成减速电机后输出扭矩 = 马达扭矩X减速比X齿轮效率;输出转速 = 马达转速 / 减速比。

· After connecting motor and gearbox which is named gearmotor the output torque: motor torque X reduction ratio X gearing efficiency; output speed: motor speed/reduction ratio.